

The Burke UMC Safe Sanctuaries Policy is a document combining:
Child Protection
Emergency Action
Disaster Preparedness



1. Missing Child, 4	
2. Media Crisis Communications, 4	
3. Emergency Chain of Command, 4	
4. Safe Sanctuaries & Building Use Agreement, 5	
5. Building Safety, 5	
6. Weapon Free Zone, 5	
7. Release of Students, 5	
8. Open Classrooms, 5	
9. Check In/Check Out Procedures, 6	
10. Open Door Policy, 6	
11. Well Child Policy, 6	
12. Medications Policy, 6	
IV. Reducing the Risk of Child Abuse.....	6
1. Six Month Rule, 7	
2. Screening, 7	
3. Staff Training, 7	
4. Two Leader Rule, 8	
5. Buddy System, 8	
6. Classroom Discipline, 8	
7. Church Liability Insurance, 8	
8. Restroom Guidelines, 9	
9. Accidental Injuries to Children, 9	
10. Adequate Supervision, 9	
V. Digital and Online Procedures.....	9
1. General, 9	
2. E-mail and Texting with Youth, 9	
3. Online Webinar/Communications Platform, 10	
VI. Procedures in Response to Allegations of Child Abuse...	11
VII. Physical Intimidation, Violence, or Threats.....	11
1. Domestic Situation, 11	
2. Church Violence/Menacing Person, 12	
3. Lock-Down Procedures, 12	
VIII. Weather Related Emergencies.....	14
1. Weather Related Information, 14	
2. Weather Related Emergency Actions, 14	
IX. Contaminants.....	15
X. Medical Emergency.....	15
1. Medical Emergency, 15	
2. First Aid, 16	
3. Checking an Unconscious Adult, 18	
4. Victim of Shock, 19	
5. Seizures, 19	
6. Stroke, 20	
7. Heart Attack, 20	
XI. Fire Emergency.....	22
XII. Power Outage.....	23
XIII. Bomb Threat.....	23
XIV. Policy Review.....	23

APPENDIX A: Evacuation/Building Maps, 24
APPENDIX B: Evacuation Rally Points, 26
APPENDIX C: Emergency Contacts, 27
APPENDIX D: Bomb Threat Checklist, 28
Appendix E: Virginia's Child Abuse Law & Types of Child Abuse, 30

I. PURPOSE

- a. To help Burke United Methodist Church provide a caring, safe, and secure environment for people in all phases of church life.
- b. To help Burke United Methodist Church reduce its legal risk and liability exposure.

II. BIBLICAL FOUNDATION

Burke United Methodist Church seeks to express God's love of all people and provide for their personal wholeness. This caring community seeks to provide safety, reduce risk, prevent child abuse, and be in ministry to all families.

For the LORD your God is God of gods and Lord of lords, the great God, mighty and awesome, who shows no partiality and accepts no bribes. He defends the cause of the fatherless and the widow, and loves the alien, giving him food and clothing. And you are to love those who are aliens, for you yourselves were aliens in Egypt. Deuteronomy 10:17-19

And they were bringing children to him, that He might touch them+, and the disciples rebuked them. But when Jesus saw it He was indignant, and said to them, "Let the children come to me, do not hinder them; for to such belongs the kingdom of God. Truly, I say to you, whoever does not receive the kingdom of God like a child shall not enter it." And He took them in his arms and blessed them, laying his hands upon them. Mark 10: 12-16

Our goal in response to God's desire for all people to be protected and loved is to maintain a safe, secure, and loving place where people can grow physically, emotionally, and spiritually.

Our Mission: *Welcoming all to learn, celebrate, and share Christ's life-changing love!*

III. FACILITY SAFETY

1. MISSING CHILD

Children are not to be unattended in the Burke UMC facility or on the grounds. The exception is when a youth is coming to or being released from an activity and/or picking up younger siblings to meet their families. The following rules are to be enforced by parents, teachers/facilitators, leaders, & staff:

- Nursery – 6th grade children are not to be unattended in the Burke UMC facility.
- Nursery – 6th grade children may not be released to any adult, older sibling, or person not listed on registration information unless noted ahead of time in writing.

In the event of a missing child:

- Notify parents (if they did not report) and get information on what the child was wearing.

- Notify other adults in vicinity immediately.
- Notify ushers/Connection Center personnel immediately.
- Spread to all doors of church to ensure that if the child is still in the building, they cannot leave.
- Check back parking lots and playground.
- Notify Pastor or staff member so announcement can be made.
- Conduct immediate search of facility & surrounding area.
- Call 911.
- Have current photo available for congregation members and emergency personnel to see. (Staff can attain.)

2. MEDIA CRISIS COMMUNICATIONS

To help ensure that all media receive accurate, identical information, please direct any and all media inquiries you might receive to the Senior Pastor. (The Senior Pastor may appoint another person to act in his/her stead.)

3. EMERGENCY CHAIN OF COMMAND

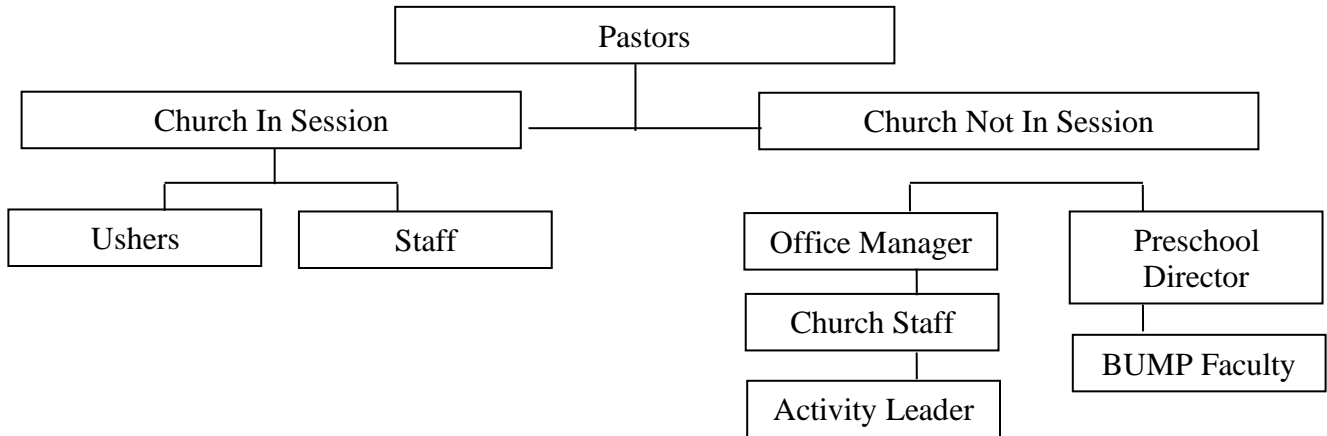

4. SAFE SANCTUARIES & BUILDING USE AGREEMENT

All organizations or persons who use the BUMC facility must be notified of and adhere to the BUMC Safe Sanctuaries policy annually. An updated & signed copy (electronic or hard copy) of the Safe Sanctuaries signature form should be kept in Sharepoint.

5. BUILDING SAFETY

- All classroom doors should have a window or a half door.
- A sign in/sign out procedure will be used for all drop-off activities for children 6th grade and below.
- 6. An appointed staff or volunteer will act as a hall monitor during Sunday School hours on the main level Children’s Wing when possible. **WEAPON FREE ZONE**
As guided by the Book of Resolutions in Resolution #3428, “Our Call to End Gun Violence”, Burke UMC is a Weapon Free Zone.

7. RELEASE OF STUDENTS

7-12th grade students will be released at the end of the Sunday School hour to meet with

their families at a predetermined location. Nursery – 6th grade students will only be released to an adult whose name is listed on the child's registration form – or an older sibling (7th grade or older) who has been listed on the registration form. Any changes must be communicated to the designated staff person in writing.

8. OPEN CLASSROOMS

Classrooms or childcare rooms may be visited without prior notice by church staff, parents, or other volunteer church workers. Brief observation of childcare rooms and classrooms of children or youth are to be conducted by the pastors or other appropriate staff during Sunday School hours. Observation of new teachers and leaders of children or youth shall take place during their first 2 months of service by a pastor or the Director of Children and Youth Discipleship.

9. CHECK-IN/CHECK-OUT PROCEDURES FOR CHILDREN UP TO 6TH GRADE

All events where parents drop off children up to 6th grade:

- The activity leader must have a permission or registration form which includes emergency contact information & consent as well as a list of adults who are authorized to sign out a minor.
- The activity leader must have an attendance sheet that they have available to check and can take with them in case of a fire drill or emergency. The activity leader will not release a minor to any unauthorized person. Authorized pick-up persons must sign out on the attendance sheet.

10. OPEN DOOR POLICY

All half doors should keep the top open at all times. Doors should never be locked while people are inside the room (preschool exception).

During preschool hours, teachers are to lock their classroom doors when there are 2 adults inside the room. They are to keep their key on their person.

During preschool hours (M-Th, 9:30AM-2PM) hallway doors are to remain closed.

11. WELL CHILD POLICY

It is our desire to provide a healthy and safe environment for all of the children at Burke United Methodist Church. Parents are encouraged to be considerate of other children when deciding whether to place a child under our care. In general, children with the following symptoms should NOT be dropped off:

- Fever, diarrhea, or vomiting within the last 48 hours
- Green or yellow runny nose
- Eye or skin infections
- Other symptoms of communicable or infectious disease

Children who are observed by our workers to be ill will be separated from other children and the parent or guardian will be contacted to request that the child be picked up for the day.

12. MEDICATIONS POLICY

It is the policy of Burke United Methodist Church not to administer either prescription or non-prescription medications to minors under our care. Medications should be administered by a parent at home. Parents are reminded of our well child policy.

Exceptions to the medications policy may be granted to parents of children with potentially life-threatening conditions (such as asthma or severe allergic reactions). Parents of such children should address their situation with the appropriate staff person to develop a plan of action.

IV. REDUCING THE RISK OF CHILD ABUSE

In an effort to create the safest possible environment within our church, several abuse prevention measures will be utilized. All paid staff members working with children will take a child abuse prevention webinar. It is encouraged that all adults volunteering with our children do the same. Other measures include “barrier crimes” background checks, , provision for regular training on child abuse issues to paid and volunteer staff members, use of the two leader rule, standards for appropriate classroom discipline and open classrooms.

1. SIX MONTH RULE FOR BUMC VOLUNTEERS & STAFF

Anyone working with children or youth at BUMC must be an active participant or a member of the church for at least six (6) months. Exceptions can be made with approval of Children & Youth Director & Senior Pastor. New workers may be assigned a mentor who will be available to assist the new worker's understanding of procedures and policy during the first six (6) months of service. The person serving as mentor should have experience in the same area of church ministry but does not have to work alongside or be in constant sight of the new worker.

2. SCREENING FOR BUMC VOLUNTEERS & STAFF

Before beginning the first year of service, each paid staff member or volunteer who works with children will be asked to attend or watch an orientation session and sign a statement indicating that he/she agrees to abide by the *Safe Sanctuaries Policy* of Burke United Methodist Church. They must also submit a “Background Authorization Form.”

For paid church staff, the BUMC Personnel Policy addresses screening. For paid preschool staff, the Preschool Handbook addresses screening.

In addition, leaders working with children or youth will undergo a national "barrier crimes" background check. Reports will remain confidential and will be reviewed only by the Pastor or designated staff member. Files containing reports on background checks will be kept in a secure area and be accessible only to the Pastor or designated staff person.

Anyone refusing to undergo a background check authorization will not be permitted to work with children. Anyone who has had a conviction, charge, or expungement of any "barrier crime" will not be permitted to work with children, however, recognizing that some barrier crimes do not involve harming children and we believe in restorative justice, the person with this record could be granted permission with the approval of the Senior Pastor, Director of Children & Youth and Leadership Board Chair..

Costs for criminal check and other such expenses will be paid by the church. Screening

requirements differ according to the extent and frequency of contact with children/youth. An outline of screening procedures follows:

Orientation and Screening Procedures for BUMC Volunteers & Staff

Requirements	Positions
1. Background Check Authorization	All adults who work or volunteer with children.
2. Safe Sanctuary Orientation	
3. Signed BUMC Safe Sanctuary Agreement (Renewed Annually)	
4. Driving record check	Only necessary if driving is part of volunteer position.
5. Follow-up report by administration (reference check, interview, annual review)	Paid staff. Only as necessary for other positions.

3. BUMC STAFF & VOLUNTEER TRAINING

Before beginning their first year of service, all paid and volunteer child/youth workers will participate in training that explains church policy, rationale, church and individual liability, indicators of child abuse, reporting, and responding procedures. This “Safe Sanctuary” training may be conducted in separate sessions and/or may be part of regularly scheduled training for the staff of BUMC Preschool and the volunteer staff that carries out programs for BUMC. Additional awareness training will be made available for all church members so that part-time child/youth volunteers as well as our church body may be part of a conscientious effort to secure a safe environment for all people. This training will be approved and implemented by designated staff. Training is renewed annually.

4. TWO LEADER RULE

Leaders will be assigned in teams of two or more for all children or youth activities. These two leaders cannot be related or cohabiting, must be adults aged 18 or older and at least 5 years older than the children and youth they are overseeing. If the group is divided into two separate rooms, each subgroup will have two leaders. If there are not two leaders available for each group, then either the group will be combined with another group to make possible the presence of two leaders, or the activity will be canceled on that occasion.

Community groups of children or youth who meet at the church must have two or more leaders present who have signed the Safe Sanctuaries Agreement. If any group stays overnight at the church, or if a church sponsored group leaves the premises, two or more leaders must be present and must include at least one male and one female who are unrelated or are not persons who are cohabiting, if the group is mixed in gender.

5. CLASSROOM DISCIPLINE

All activity leaders and workers with children and youth will use the following discipline measures:

If a child is having difficulty with behavior expectations, one of the adults working with the group will remind the class and child what the expectations are for the activity. The leader will state what the expectation is clearly and succinctly. If this measure is not effective, the child will

be redirected to a separate space within the room and offered a moment to reset or to use a calming strategy (provided by the Director or Children and Youth Discipleship). If the unexpected or unsafe behavior continues, the child may be placed at a table to work alone away from the other students. The Director of Children and Youth Discipleship will be contacted to assist. If the child's disruptive behavior continues after these steps have been taken, the child may be taken to their parent, guardian or appropriate staff person.

No physical punishment or verbal abuse (i.e., ridicule) is to be used at any time. If isolating the child within the classroom or removal of the child from the room becomes necessary, the situation will be discussed with the appropriate staff and the child's parents or guardian as soon as possible. Documentation of the situation and steps used will be required after the activity, to assist in future de-escalation success.

6. CHURCH LIABILITY INSURANCE

The BUMC Board must insure BUMC carries adequate liability insurance coverage that applies to all of the different activities of the church, at and away from church premises, and it should work with a knowledgeable insurance agent who knows and understands the needs of a church.

7. RESTROOM GUIDELINES (for children 6th grade and under)

It is strongly encouraged that children use the restroom right before being dropped off at any activity. In situations where a child needs to go to the restroom, prop the door open. The second adult should check the bathroom to make sure that it is empty, and the second adult should then stand at the classroom door to be able to see both the classroom and the bathroom. . If a child is taking longer than seems necessary, the worker should open the bathroom door and call the child's name. If a child requires assistance, another adult needs to be called to stay in the hallway with the group. Once there are at least 2 adults, the workers should prop open the bathroom door and leave the stall door open as he/she assists the child. If the child cannot follow the guidance of the worker without needing physical help, the parent should be called and made aware of what happened and why the child required assistance.

For the protection of all, workers should *never* be alone with a child in a bathroom with the door closed or open; and never be in a closed bathroom stall with a child.

8. ACCIDENTAL INJURIES TO CHILDREN

In the event that a child or youth is injured while under our care, the following steps should be followed:

1. For minor injuries, scrapes, and bruises, workers will provide First Aid (Band-Aids, etc.) as appropriate and will notify the child's parent or guardian of the injury at the time the child is picked up from our care.
2. For injuries requiring medical treatment beyond simple First Aid, the parent and/or guardian will immediately be summoned in addition to the worker's supervisor. If warranted by circumstances, an ambulance will be called.
3. Once the child has received appropriate medical attention, an incident report will be completed in the case of injuries requiring treatment by a medical professional.

9. ADEQUATE SUPERVISION

Adequate supervision will be provided at all times. For church or outside groups, the below ratio must be followed. For our weekday preschool, their ratio can be attained by the Preschool

Director:

- One adult to three children, zero to twelve months of age.
- One adult to four children, ages twelve to twenty-four months
- One adult to six children, ages twenty-four months to thirty-six months
- One adult to eight children, ages three to eighteen years

The specific needs of individual children may require a change to these guidelines. We require two adults at all times, these ratios are intended for ratios within larger groups or activities in the same area.

V. DIGITAL & ONLINE PROCEDURES

1. General

Follow all Safe Sanctuaries policies.

- All Safe Sanctuaries policies still apply in an online environment. Ensure you always have two unrelated adults present for online activities and meetings. This is required when meeting with minors in person, online, or through a web format.
- All aspects of Burke UMC's programming is open to observation by parents and pastors. Ensure meeting and login information has been shared with parents and pastors prior to meeting date.
- Make notes about attendance and plan group chats/online activities when possible. Document who is there, just as you would take attendance in person.

2. Email & Texting with Youth

- With parent consent (included as part of the registration form) adult youth leaders and youth may communicate (email/text) without parents included. When permission is given, it is VERY important for that adult to have a written record and the conversation be sent to a pastor. A pastor will save this and keep it in confidence
-
- Youth leaders may send group texts or emails out to 3 or more youth without including parents as long as 2 unrelated adult leaders are included on the communication.
- If one-on-one texting or e-mailing occurs outside of the conditions above:
Inform a parent/guardian. If it is a scheduled conversation, inform prior to occurrence. If it is not, inform parent/guardian following the conversation. If the topic is confidential (remember that confidentiality is different than secrecy), then a pastor should be notified. The content of the conversation can remain private unless it is reportable according to the larger Safe Sanctuary guidelines.
- Staff members should only use @burkeumc.org email addresses to communicate with minors – not personal accounts unless approved by senior pastor.

3. Online Webinar/Communications Platforms

- a. Use business-oriented conference platforms that include good safety and privacy features instead of platforms with other primary purposes (such as gaming).
 - i. Review the terms of service, safety and privacy features, and data collection policies of any platform you use.

- b. Regularly review and implement the latest security features of your chosen platform to avoid unauthorized visitors or other security issues in your meetings.
 - i. Just as you put in place plans for the physical security of your meeting place, here are some tips to consider as you get started developing your own strategy to manage online security:
 1. Use unique meeting identification numbers for each session.
 2. Utilize password features for all meetings.
 3. Do not publish meeting invitations via public forums and remind attendees not to pass along invitations.
 4. Use “waiting room” features to manage letting individuals into your meetings.
 - ii. Disable features that you will not need, such as screen-sharing by non-hosts, private chats, and whiteboards.
- c. Do not record online activities/meetings that include youth participants.
- d. Recording of online activities that only involve adults can only be done with approval of participants.
- e. Safeguard personal information.
 - i. If you collect a person’s personal information online—for example, through web forms used to register people for online meetings—then that information is to remain private and only used for Burke UMC communications needs. Contact lists should not be shared with other people.
- f. Adult leaders and participants must use real names, not handles, on church related platforms. When possible, we strongly encourage videos to be on in zoom-like settings.

VI. PROCEDURES IN RESPONSE TO ALLEGATIONS OF CHILD ABUSE

Should there be an allegation of child abuse at Burke United Methodist Church, the following procedures shall be followed:

1. If child abuse is reported or suspected, immediately notify the pastor or designated staff member. Any allegation of child abuse will be treated seriously and be reported to the Virginia Department of Social Services of the allegation. (800) 552-7096) by the pastor or designated staff member immediately. The staff member will be advised by Social Services about what they may or may not share with the family of the victim.

If the allegations involve the Pastor or the pastor’s family, the Chairperson of the Board shall be notified immediately, and he or she shall immediately notify the District Superintendent who shall direct the next steps taken by the church in responding to the allegations. The provisions of this Policy shall continue to apply except as the District Superintendent directs the other steps be taken.

2. Pray for the church and all persons affected by the allegation.
3. Immediately begin documenting all procedures which occur in handling the allegation.
4. **Do not confront the accused with the allegation.** If the accused has assigned duties within

the life of the church and the pastor or designated staff person determines it appropriate, that person must be temporarily relieved of their duty.

5. The Pastor should extend whatever care and resources are necessary to those impacted by the allegation, but under **no** circumstances should the Pastor or any church leader or member investigate the allegation. In providing care to the principals (alleged victim and the accused) and their families, the Pastor or church leader, should under **no** circumstances be drawn into a discussion of the truth or falsity of the allegation which could contaminate the investigation. Do not assign blame or take any steps that involve establishing or refuting the allegation.

6. It is appropriate to show care and comfort for the alleged victim. This should be the pastoral objective from the moment the allegation is received or otherwise made known.

7. Observe confidentiality for both the alleged victim and the accused.

VII. PHYSICAL INTIMIDATION, VIOLENCE, OR THREATS

1. SUSPICIOUS PERSON OR BEHAVIOR

- a. Inform another staff or church member what you are doing & ask them to accompany you before approaching the intruder.
 - b. Politely greet the intruder & identify yourself.
 - c. Ask the intruder the purpose of his/her visit. If possible, attempt to identify the individual and/or vehicle. (Use phone to take photo if available.)
 - d. If the intruder's purpose is not legitimate, ask him/her to leave & accompany the intruder to the exit.
 - e. Notify the church staff of the incident.
3. If the intruder refuses to leave:
- a. Notify a staff or church member to call the police.
 - b. Give the police a full description of person & behavior.
 - c. Back away from the intruder if he/she indicates a potential for violence. Allow an avenue of escape, do not block the way out for the intruder.
 - d. Be aware of the intruder's actions at this time (where he/she is located in the building, whether he/she is carrying a weapon or package, etc.)

2. DOMESTIC SITUATION

1. Remain calm.
2. If it is safe to do so, alert other people that an emergency or danger is present or imminent; and quietly leave the area.
3. If you observe volatile behavior, politely ask to intercede.
 - a. Continue to monitor the situation.
 - b. If it accelerates, call 911.
4. Notify senior pastor or staff.

3. CHURCH VIOLENCE/MENACING PERSON

If a violent incident occurs at BUMC, the first priority is to protect the people of our congregation. The following steps should be followed:

1. Call 911.

2. If there is an opportunity to keep the invader out by locking doors and/or closing off areas of the church, do so.
3. If there is an opportunity to remove all members and guests from the premises, do so as quickly as possible. (If two adults are present, one adult should alert children and other people present to quietly leave the area.)
4. Remain calm and cooperate with the person(s); make no sudden movements.
5. Quickly control panic situations. By doing so, you will be more likely to conduct a sequenced evacuation, if possible.
6. A pastor, staff member, or usher should take charge and provide orders to be followed. (If none of those positions are present, you are in charge.)
7. All orders must be clear and direct, such as the following:
 - a) "Ushers, secure the building."
 - b) "(Name), contact the police."
 - c) "(Name), secure the nursery."
 - d) "Everyone take cover on the floor."
8. Volunteers should take precautions when in the building alone. Staff should avoid working alone when possible. When working alone is necessary, staff should be mindful and take appropriate precautions including locking all doors.
9. All church doors should be locked except when in use and then access points should be unlocked only if necessary. (During most operating hours, all BUMC doors remain locked other than the main entrance closest to the office.)

4. LOCK-DOWN PROCEDURES

In general, there are two main lockdown situations:

- Lockdown with warning: The threat is outside the church building.
- Lockdown with intruder: The threat or intruder is inside the church building.

1. Lockdown with Warning Procedures

The following procedures should be followed when the threat is outside of the church building:

- Pastor or staff person orders and announces, "lockdown with warning." Be direct. **DO NOT USE CODES.** This announcement should be repeated several times.
 - Important:
 - Special attention should be paid to classes that are outside of the church building, such as the playground, garden, or outdoor learning platform.
 - Teachers must be able to hear the lockdown announcement.
 - An alternate lockdown location must be identified. This location can be indoors or outdoors (if students can be safely hidden).
- Lock exterior doors.
- Clear hallways, restrooms, and other rooms that cannot be secured.
- Secure and cover classroom windows if possible.
- Move all people away from the windows.
 - Take attendance of students in each classroom.
 - Teachers should prepare a list of missing and extra students in the room.
 - Teachers should take this list with them once they are directed to leave the classroom.
- Control all movement but continue classes. Move on announcement only.
- Once the threat has subsided, the Office Manager or Property Manager announces,

“all clear.”

2. Lockdown with Intruder Procedures

The following procedures should be followed when the threat or intruder is inside of the church building:

- Pastor or staff person orders and announces, “lockdown with intruder.” Be direct. DO NOT USE CODES. This announcement should be repeated several times.
- Immediately direct all students, staff, and visitors into the nearest classroom or secured space.
- Classes that are outside of the building SHOULD NOT enter the building.
- Move outside classes to the posted assembly point or other safe area.
- Lock classroom doors if possible.
- Release the black out blinds at top of door (so no one can see inside the room)
- DO NOT lock exterior doors.
- Move people away from the windows and doors. Keep all students sitting on the floor together and turn off the lights.
- Take attendance of students in each classroom.
- Teachers should prepare a list of missing and extra students in the room.
- Teachers should prepare to take this list with them once they are directed to leave the classroom.
- DO NOT respond to anyone at the door until “all clear” is announced.
- Turn phones to silent, but keep on to communicate with staff/pastors/etc
- Keep out of sight.
- Be prepared to ignore any fire alarm activation, as the church will not be evacuated using this method.
- When or if students are moved out of the classroom, assist them in moving as quietly and quickly as possible.
- When the threat is over/the intruder has left the building, the building administrator announces, “all clear.”

VIII. WEATHER RELATED EMERGENCIES

1. WEATHER RELATED INFORMATION

Blizzards

1. Monitor approaching winter storm conditions, such as freezing rain, sleet, heavy snow, sustained high winds, and wind-chill conditions.
2. Ensure that employees/volunteers are aware of cold weather safety rules and understand policies for operating or closing under adverse weather conditions. (Burke UMC follows the closing policies of Fairfax County Public School. Exceptions are made at the direction of the staff, and the congregation is notified through e-mail, web site, social media, and phone calls if necessary.)

Floods

1. Monitor weather reports.
2. Secure the building, closing windows and inside doors.
3. In heavy rains, be aware of flash floods. If you see any possibility of a flash flood occurring, evacuate.
4. If you are advised to evacuate, calmly leave immediately.

Lightning

- 1. When a thunderstorm threatens, go immediately inside for protection.
- 2. Indoors, stay away from windows.

Tornadoes, Severe Thunderstorms, & Hurricanes

- 1. A “Watch” means weather conditions are favorable to the formation of a bad storm. Listen closely to emergency stations and be prepared to take action in the event a warning is released.
- 2. A “Warning” means a storm has been sighted in the area. Immediately notify building occupants to shelter-in-place.

2. WEATHER RELATED EMERGENCY ACTIONS

- 1. If you are a building leader, use your location’s weather alert media channel or service to monitor the approach and severity of the weather.
- 2. If the Weather Service issues a severe weather or tornado warning for your immediate area, warn all individuals:
 - a. Using the “all call” function on the telephones.
 - b. Verbally and/or by using a megaphone (located in emergency kits).
 - c. If during worship, by alerting the pastor to make announcement from pulpit.
- 3. Discourage occupants from leaving the building.
- 4. Close all doors; stay away from windows.
- 5. Move to your shelter-in-place areas.
- 6. If you are the designated leader, get an emergency kit and bring it to your shelter location.
- 7. Remain in the shelter area until an all-clear is given.
- 8. Reconvene building occupants when the emergency is past to make sure everyone is safe.

The Lead Usher or Activity Leader is asked to set his/her phone to receive information from the Fairfax County Community Emergency Alert Network (CEAN).

Shelter-In-Place

Best Locations	Areas to Avoid
<ul style="list-style-type: none"> • Youth Wing • Inside walls on opposite side from the direction the storm is approaching. • Interior hallway in basement (no windows; doors secured at either end) • Restrooms without windows 	<ul style="list-style-type: none"> 4. Fellowship Hall 5. Sanctuary 6. Narthex 7. Entryway 8. Rooms with windows

Emergency Kits containing the following will be located in: Church Office, Preschool Office, Kitchen, Education Wing Basement (Near B2), basement under sanctuary (near room B12), and basement under Music Wing (near B7).

- 9. First aid supplies with instructions, Pager, Latex gloves, Flashlights/batteries, Portable am/fm radios/batteries, Two-way radios, NOAA Radio/batteries, Megaphone, Duct Tape, Map of building, Bottled Water, Diapers

Outdoor Assembly Points:

These positions are noted with a posted sign.

10. Handicapped Parking in Circular Drive
11. Parking lot adjacent to Burke Centre Pkwy
12. Southeast Corner of Parking Lot on Burke Lake Road

IX. CONTAMINANTS

In the event that hazardous materials have been released into the atmosphere, occupants of the building will be asked to go to the shelter-in-place locations listed in the previous section. You would be notified of a need to take shelter by emergency personnel, local authorities, or information provided by emergency alert.

13. Shut & secure exterior doors.
14. Ask that nobody leave the building.
15. Take the first aid kits & emergency kits to the shelter location.
16. Keep an attendance record of who is present. Get names & phone numbers.
17. Close all windows, cover all vents with plastic secured by duct tape, and seal windows & doors with duct tape. (Supplies located inside emergency kits.)
18. Stay away from windows & doors as much as possible.
19. Someone should turn off the HVAC systems in the area of Shelter-in-Place thermostats.
20. Be quiet, remain calm, await instructions.
21. Unless there is an imminent threat, contact family members of those present to let them know that their child/loved one is at the church in a shelter-in-place.
22. Stay in shelter until emergency personnel or church spokesperson alerts you that the danger is over.

X. MEDICAL EMERGENCY

1. MEDICAL EMERGENCY

In the event of an injury or other medical emergency, follow these guidelines:

1. Call 911
 - a. Identify your location
 - b. Describe the situation
 - What has happened?
 - What types of injuries are there?
 - What kind of help is needed?
2. Obtain or provide on-site first aid. (First aid kits can be found in the BUMC kitchen, basement kitchenette, the Dock, and main office corridor on the boxes. Room maps note the location of First Aid kits.)
 - a. Defibrillators can be found upstairs:
 - i. On the wall in the Narthex (outside the sanctuary)
 - ii. On the wall outside Room 6
 - b. Downstairs
 - i. In the Dock
3. Alert any necessary individuals that an emergency is occurring.
4. Ask who is trained/certified, so they can take the lead.
5. Alert staff or group leader so that access to emergency records can be attained.
6. Alert family as appropriate.
7. Send someone to the parking lot to direct the emergency team.

2. FIRST AID

According to the American College of Physicians, an emergency can best be handled by remembering four things: Prevent, Prepare, Recognize, and Act. By taking these steps and applying them to a church setting, you will be better able to protect the people and ministries at Burke UMC. The following describes each of these steps in detail.

Visual reminders of these will be placed at connection center, office, and the kitchen.

Prevent:

- Before beginning any job or activity, leaders should always determine the abilities and limitations of the participants. Ask yourself what risks there may be in doing the job or activity.
- Inspections also can be a great deterrent in preventing unwanted accidents. It is important to look at the location and equipment being used to determine if they are safe.

Prepare:

- Whenever possible, have emergency contact information for group members.
- Know the location of the nearest land-line telephone & first-aid kit.

Recognize:

- When something serious happens, it is important to be able to distinguish between what is minor versus injuries that are life threatening. Caution should be used. Without any training or knowledge, an injury could be compounded.

Act:

Once you have made a determination that something needs to be done, it is time to act. The following are steps to take when responding to an emergency:

- Call 911.
- Act immediately.
 - Look for a medical ID tag or bracelet on the person's wrist, neck, or ankle.
 - Determine if the person can move his or her body without any pain.
- If the person can move his or her body without any pain, and there are no other signals of injury, have him or her attempt to rest in a sitting or other comfortable position.
- Check breathing. [See chart on page 12]
- Stop any bleeding. A snug bandage or pressure dressing can often stop or slow bleeding. If this does not work, press firmly at the point that cuts blood flow off to the injured area.
- Check for shock. Is the face drained of color, skin cold and moist? Is there a rapid, weak pulse or fainting? If so, have the victim lie down and attempt to calm them. [Chart pg. 13]
- Give attention to the possibility of poisoning. If poisoning is suspected, call the Nationwide Poison Center at (800) 222-1222 and 911 if necessary.

- Should You Move Them? Unless the victim is in immediate danger, do not attempt to move them.
- If a broken bone is obvious, keep the extremity still so that the joints are immobilized.
- Treat burns. Burns may be caused by chemicals or heat.
 - Check for life-threatening conditions.
 - Cool the burn with large amounts of cold running water.
 - Cover the burn loosely with a sterile dressing.
- DO NOT:
 - Apply ice or ice water. Ice can cause the body to lose heat & cause further damage.
 - Touch a burn with anything except a clean covering.
 - Remove pieces of clothing that stick to the burned area.
 - Try to clean a severe burn.
 - Break blisters.
 - Use any kind of ointment.
- Bandage wounds. When it is necessary to bandage a wound, a sterile dressing should be used. This will help keep infection down, reduce bleeding and lessen pain.

CRITICAL FACTS

DON'T SECOND GUESS—CALL 9-1-1

Call 9-1-1 or the local emergency number if the person—

- Is unconscious, unusually confused or seems to be losing consciousness.
- Has trouble breathing or is breathing in a strange way.
- Has chest discomfort, pain or pressure that persists for more than 3 to 5 minutes or goes away and comes back.
- Has pressure or discomfort in the abdomen that does not go away.
- Is vomiting blood or passing blood.
- Has a seizure lasting more than 5 minutes or has multiple seizures.
- Has a seizure and is pregnant.
- Has a seizure and is diabetic.
- Has a severe headache or slurred speech or other trouble speaking.
- Has weakness or numbness in his or her body.
- Appears to have been poisoned.
- Has injuries to the head, neck or back.
- Has possible broken bones.

FAST RECOGNITION OF STROKE

For a stroke, think **FAST!**

- **Face**—Weakness on one side of the face (Fig. 9-3, A).
 - Ask the person to smile. This will show if there is drooping or weakness in the muscles on one side of the face.
- **Arm**—Weakness or numbness in one arm (Fig. 9-3, B).
 - Ask the person to raise both arms to find out if there is weakness in the limbs.
- **Speech**—Slurred speech or trouble speaking.
 - Ask the person to speak a simple sentence to listen for slurred or distorted speech. Example: "I have the lunch orders ready."
- **Time**—Time to **CALL 9-1-1** or the local emergency number if you see any of these signals.
 - Note the time that the signals began and call 9-1-1 or the local emergency number right away.

FIGURE 9-3, A-B

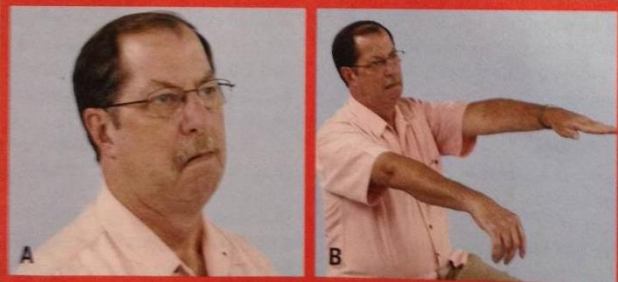

Checking an Unconscious Adult

(APPEARS TO BE UNCONSCIOUS)

FOR ADULT (AGE 12 OR OLDER)

1. Wear disposable gloves and

FIGURE 3-17, A-C A, Help a victim of shock lie down. B, Elevate the person's legs about 12 inches. C, Keep the person from getting chilled or overheated.

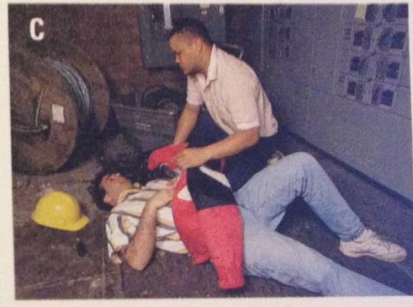
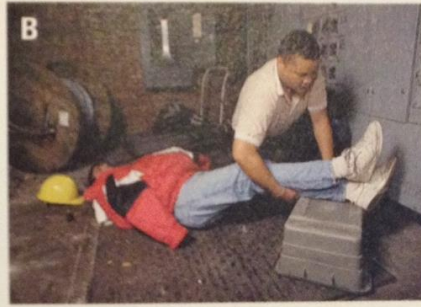
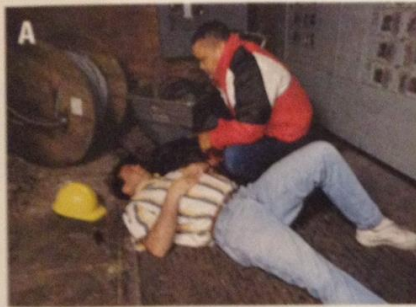

- Help the person maintain normal body temperature (Fig. 3-17, C). If the person is cool, try to cover him or her to avoid chilling.
- Do not give the person anything to eat or drink, even though he or she is likely to be thirsty. The person's condition may be

severe enough to require surgery, in which case it is better if the stomach is empty.

- Reassure the person.
- Continue to monitor the person's airway, breathing and circulation.

SEIZURES

When the normal workings of the brain are disrupted by injury, disease, fever or infection, the electrical activity of the brain becomes irregular. This can cause a loss of body control known as a *seizure*. Seizures may be caused by extreme heat, a diabetic condition or an injury to the brain.

Seizures may be caused by an acute or chronic condition. The chronic condition is known as *epilepsy*. Over 2 million Americans have epilepsy. Epilepsy is usually controlled with medication. Still, some people with epilepsy have seizures from time to time. Others who go a long time without a seizure may think the condition has gone away and stop taking their medication. These people may then have a seizure again.

A person with epilepsy may experience something called an *aura* before the seizure occurs. An aura is an unusual sensation or feeling such

as a visual hallucination; strange sound, taste or smell; or an urgent need to get to safety. If the person recognizes the aura, he or she may have time to tell bystanders and sit down before the seizure occurs.

Seizures range from a blank stare or period of distorted sensation during which the person is unable to respond to sudden, uncontrolled muscular contractions called *convulsions*, which last several minutes. Infants and young children are at risk for seizures brought on by high fever. These are called *febrile* (heat-induced) *seizures*.

Although it may be frightening to see someone unexpectedly having a seizure, you should remember that most seizures last only for a few minutes and the person usually recovers without problems.

CRITICAL FACTS

FAST RECOGNITION OF STROKE

DID YOU KNOW?

ASPIRIN CAN LESSEN HEART ATTACK DAMAGE

You may be able to help a conscious person who is showing early signals of a heart attack by offering him or her an appropriate dose of aspirin when the signals first begin. However, you should never delay calling 9-1-1 or the local emergency number to do this. Always call 9-1-1 or the local emergency number as soon as you recognize the signals, and then help the person to be comfortable before you give the aspirin.

Then, if the person is able to take medicine by mouth, ask if he or she—

- Is allergic to aspirin.
- Has a stomach ulcer or stomach disease.
- Is taking any blood thinners, such as Coumadin™ or Warfarin™.
- Has been told by a doctor not to take aspirin.

If the person answers no to all of these questions, you may offer him or her two chewable (162 mg) baby aspirins, or up to one 5-grain (325 mg) adult aspirin tablet with a small amount of water. Be sure that you only use aspirin and not Tylenol, acetaminophen, Motrin, Advil or ibuprofen, which are painkillers. Likewise, do not use coated aspirin products or products meant for multiple uses such as cold, fever and headache.

You may also offer these doses of aspirin if you have cared for the person and he or she has regained consciousness and is able to take the aspirin by mouth.

Medical services (EMTs) workers in 1997. The to help paramedics identify strokes in the field. prepare the emergency room before they arrive. This method for public awareness has been in use in the community in Cincinnati, Ohio since 1999, and has since been used in several other variations of the message. It was validated by researchers at the University of North Carolina in 2003.

CRITICAL FACTS

CARE FOR A HEART ATTACK

- Recognize the signals of a heart attack.
- Call 9-1-1 or the local emergency number immediately for help.
- Convince the person to stop activity and rest.
- Try to obtain additional information about the person's condition.
- Comfort the person.
- Assist with medication, if prescribed.
- Offer an aspirin, if medically appropriate and local protocols allow (see page 70).
- Monitor the person's condition.
- Be prepared to give CPR and to use an AED.

XI. FIRE

EMERGENCY

All staff and volunteer leaders should evaluate the building to ensure they have a working knowledge of where classrooms & exits are located. You should know who would need to be evacuated in case of fire (building occupants), the physical features of our building, the location of emergency resources in each area of our facility, and where to evacuate and assemble in a safe location outside the building while you wait for the fire department.

All classrooms at Burke UMC have an evacuation map posted on the wall. Note your location & the closest exits to your position. The map also indicates the location of first-aid kits, emergency kits, and assembly locations.

One of more of the following actions can activate a fire alarm:

- A person activates the fire alarm pull box.
- A smoke detector senses smoke.
- An automatic sprinkler activates.

When the fire alarm is activated:

- The fire systems horns sound a pattern of pulsating tones and the strobe lights also indicate alarm activation.
- The alarm monitoring company receives automatic notification when an alarm is activated and contacts the Fairfax County Emergency Communications Center.

If an individual sees fire or detects smoke or a burning odor, the following actions should be taken:

- Do not use elevators.
- Pull the closest fire alarm to initiate building evacuation.
- If there is no immediate danger to yourself or others, if the fire is smaller than a basketball, and if it is not between you and the exit, you may use the nearest fire extinguishers to fight the fire
 - PASS
 - Pull
 - Aim
 - Squeeze
 - Sweep
- Call 911.
- If church is in session:
 - A pastor or Head Usher should make an announcement that all persons should leave the building and assure parents that their children's teacher will take them to the designated assembly areas.
 - The Head Usher will be responsible for the safe evacuation of the congregation to exit the building. The usher/greeter team will help instruct and guide the congregation in exiting the building and going to the designated safe place. The Head Usher or designee will walk through the sanctuary and surrounding areas to see if anyone is left behind and report results to the fire department. The staff will assist.
- Meet at assembly points. [Appendix A]

- Account for all individuals once assembled.
- Follow all instructions from the fire department and police.
- Do not go back into the building. (Re-enter only after the all-clear is given by the fire department.)

XII. POWER OUTAGE

23. Assess the extent of the outage using flashlights located in the supply kits.
24. If an outside group, report the outage to number listed on your building use form
25. Help occupants in darkened work areas move to safe locations.

XIII BOMB THREAT

26. Precautions: Do not use cellular phone or two-way radios (this may activate electronic trigger mechanisms).
27. Open all doors and windows of evacuated areas.
28. Avoid the elevators if possible.

Critical Information:

29. All bomb threats must be taken seriously until they are assessed.
30. The decision whether or not to evacuate rests with the church, not the responding agencies, unless a device is located.

Procedures upon receiving a bomb threat:

31. By phone call: complete the checklist for telephone threats [APPENDIX E]
 - Be calm and courteous. Listen; do not interrupt.
 - Use the following Bomb Threat checklist to record all information provided by the caller.
 - After the caller hangs up, call 9-911 immediately.
 - Take the checklist with you as you evacuate the building.
32. By written note:
 - Notify the staff to contact the police.
 - Preserve the evidence, in plastic bag if available.
 - Photograph words written on walls.
33. If you find an item you suspect is a bomb:
 1. Do NOT touch, move, or disturb the item.
 2. Immediately call 911 or other designated emergency number on your Local Emergency Contact Numbers list (page 4).
 3. Notify appropriate members on your Member Emergency Contact list (page 4).
 4. Keep everyone away from the area until help arrives.

XIV. POLICY REVIEW

The Safe Sanctuaries Policy of Burke United Methodist Church shall be reviewed annually by the Board.

APPENDIX A: Evacuation Maps

UPPER LEVEL



Assembly Point at rear of preschool parking lot

Indicates Moveable Wall

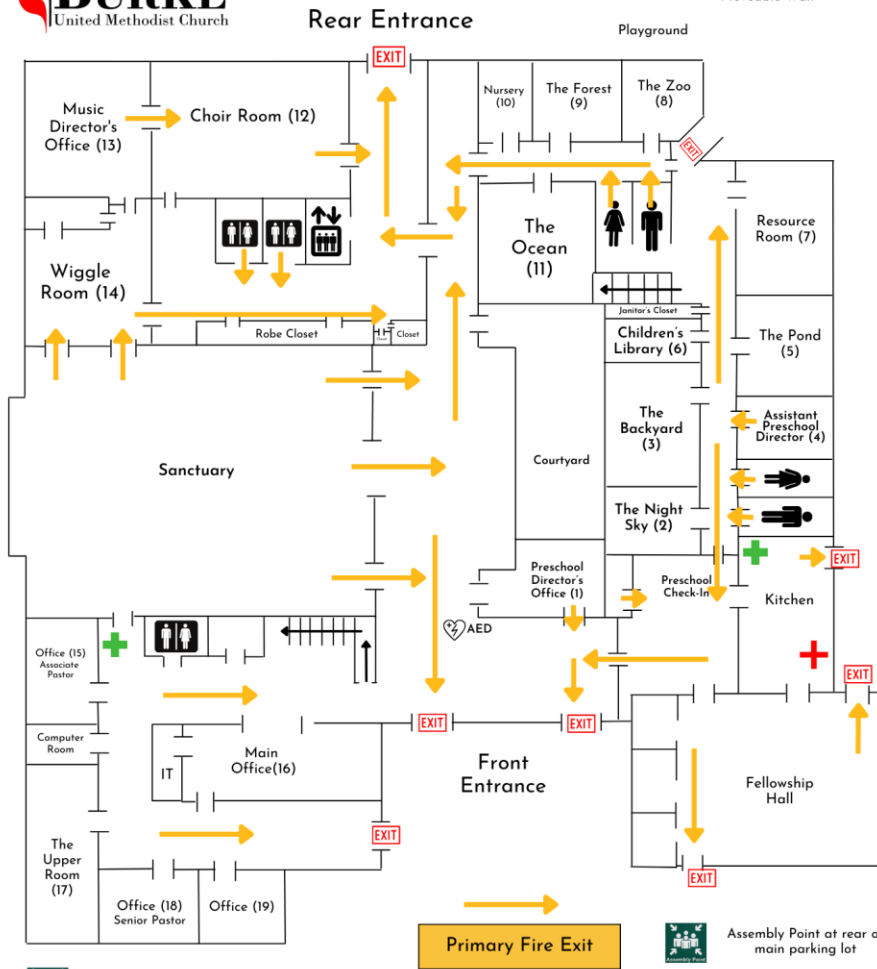

Assembly Point at far corner of parking lot

Shelter in place in lower level rooms 20, 21, 22

<p>Burke United Methodist Church 6200 Burke Centre Parkway Burke VA 22015</p> <p>703.250.6100</p> <p>Located at the intersection of Burke Lake Road and Burke Centre Parkway</p>	<p>In case of emergency, dial 911</p> <ul style="list-style-type: none"> + First Aid Kit + Emergency Kit Assembly Point
---	--

APPENDIX A: Evacuation Maps

LOWER LEVEL



Assembly Point at rear of preschool parking lot

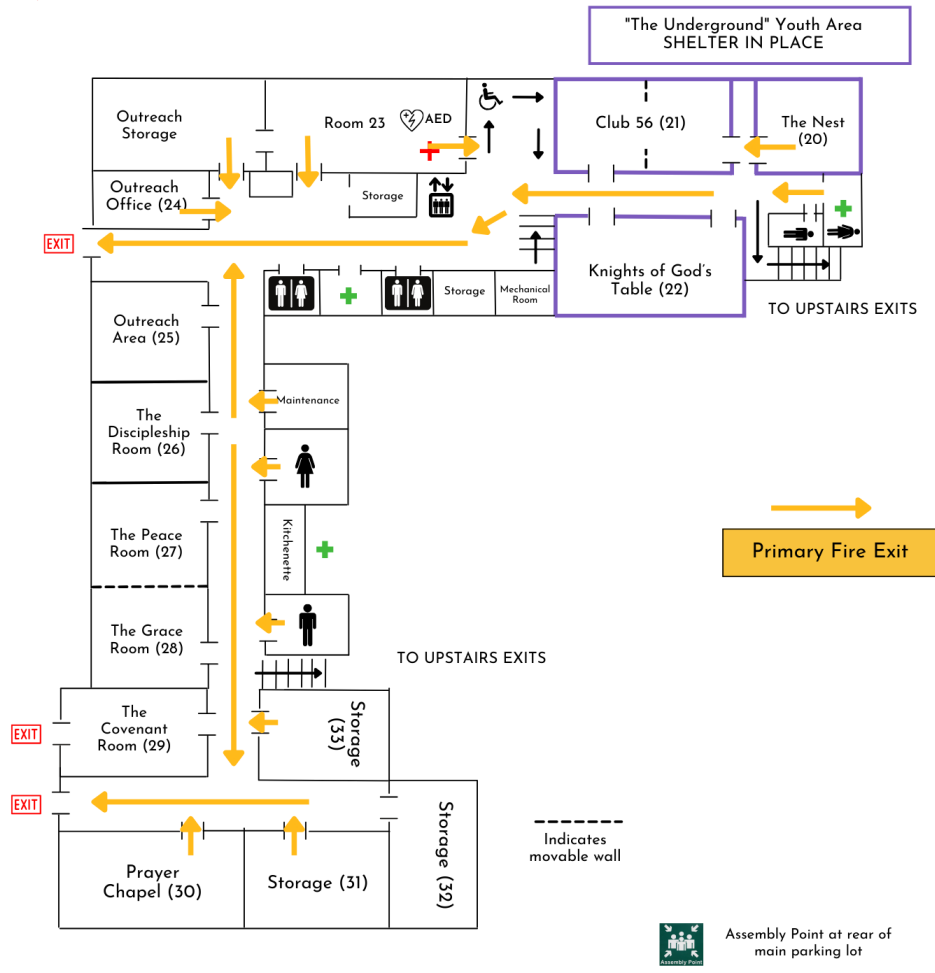

Assembly Point at far corner of parking lot

Assembly Point at rear of main parking lot

<p>Burke United Methodist Church 6200 Burke Centre Parkway Burke VA 22015</p> <p>703.250.6100</p> <p>Located at the intersection of Burke Lake Road and Burke Centre Parkway</p>	<p>In case of emergency, dial 911</p> <p> First Aid Kit</p> <p> Emergency Kit</p> <p> Assembly Point</p>
---	---

APPENDIX B: Evacuation Rally Points

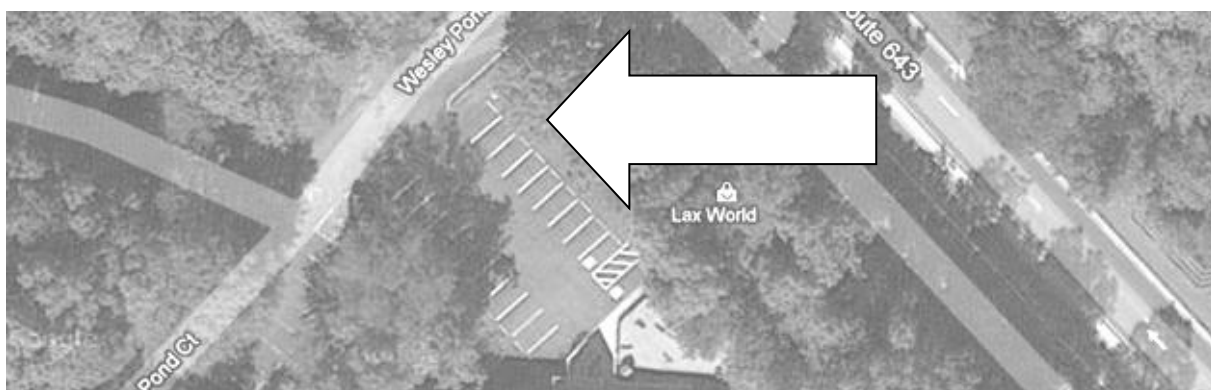

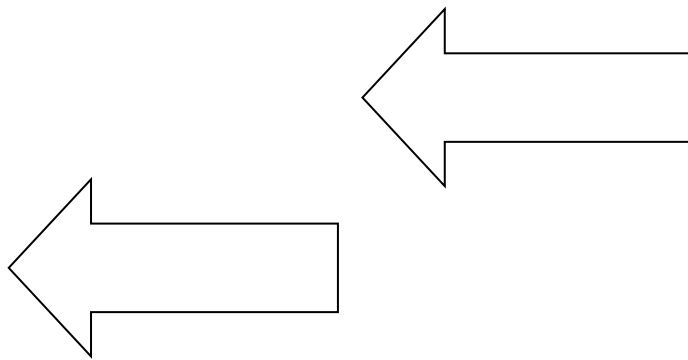

APPENDIX C: Emergency Contacts

EMERGENCY	911
Police Non Emergency	703-691-2131
Fire Non Emergency	703-978-9200
Fairfax County Emergency Information Line	703-817-7771
Poison Control Center	800-222-1222
Fairfax County Schools Emergency Hotline	800-839-3277
Suicide Prevention	703-527-4077
Fire Alarm Company (Siemens)	301-987-1200

Updated: 9/2024

UTILITIES	
Telephone (Verizon)	800-275-2355
Gas (Washington Gas)	703-750-1400
Water (Ffx Cty Water Authority)	703-698-5800
Sewer (Ffx Cty Public Works)	703-323-1211
Miss Utility	800-552-7001
Dominion Power	888-667-3000
OTHER IMPORTANT NUMBERS	
ATF	703-286-1110
State Police	800-572-4510
Secret Service	202-406-8000
FBI	202-278-2000
Poison Control Center	800-222-1222

APPENDIX D: Bomb Threat Checklist

Bomb Threat Checklist

Be calm. Be courteous. Listen. Do not interrupt.

Name:		Time of call: Start: End:	Date of call:
Dept.:	Number where call was received:		

Exact words of the caller:

Questions to Ask

Bomb Threat Checklist (Continued)

Call Details:

If the voice is familiar, who does it sound like?

Description of Caller's Voice and Speech Patterns:

- | | | | |
|---|--|--|--|
| <input type="checkbox"/> Adult | <input type="checkbox"/> Youth | <input type="checkbox"/> Disguised | <input type="checkbox"/> Ragged |
| <input type="checkbox"/> Male | <input type="checkbox"/> Female | <input type="checkbox"/> Distinct <input type="checkbox"/> Slurred | <input type="checkbox"/> Raspy |
| <input type="checkbox"/> Accent | <input type="checkbox"/> Excited | <input type="checkbox"/> Reading message | <input type="checkbox"/> Slow <input type="checkbox"/> Rapid |
| <input type="checkbox"/> Angry | <input type="checkbox"/> Foul language | <input type="checkbox"/> Soft <input type="checkbox"/> Loud | <input type="checkbox"/> Speech impediment |
| <input type="checkbox"/> Calm | <input type="checkbox"/> Incoherent | <input type="checkbox"/> Stuttering | <input type="checkbox"/> Taped message |
| <input type="checkbox"/> Clearing throat | <input type="checkbox"/> Irrational | <input type="checkbox"/> Well spoken | |
| <input type="checkbox"/> Cracking voice | <input type="checkbox"/> Laughing | | |
| <input type="checkbox"/> Crying | <input type="checkbox"/> Lisp | | |
| <input type="checkbox"/> Deep <input type="checkbox"/> High | <input type="checkbox"/> Nasal | | |
| <input type="checkbox"/> Deep/unusual breathing | <input type="checkbox"/> Normal | | |

Description of Background Noises:

- | | | |
|-----------------------------------|--|--|
| <input type="checkbox"/> Aircraft | <input type="checkbox"/> Local | <input type="checkbox"/> Office/office machinery |
| <input type="checkbox"/> Animal | <input type="checkbox"/> Long distance | <input type="checkbox"/> PA system |
| <input type="checkbox"/> Clear | <input type="checkbox"/> Machinery | <input type="checkbox"/> Quiet |
| <input type="checkbox"/> Dishes | <input type="checkbox"/> Motor | <input type="checkbox"/> Static |

APPENDIX E: Virginia's Child Abuse Law & Types of Child Abuse

Under Section 63.2-100 of the Code of Virginia, an abused child is defined as one who is less than eighteen years of age,

1. Whose parents or other person responsible for his care creates or inflicts, threatens to create or inflict, or allows to be created or inflicted upon such child a physical or mental injury by other than accidental means, or creates a substantial risk of death, disfigurement, or impairment of bodily or mental functions, including but not limited to, a child who is with his parent or other person responsible for his care either (i) during the manufacture or attempted manufacture of a Schedule I or II controlled substance, or (ii) during the unlawful sale of such substance by that child's parents or other person responsible for his care, where such manufacture, or attempted manufacture or unlawful sale would constitute a felony violation of § 18.2 248;
2. Whose parents or other person responsible for his care neglects or refuses to provide care necessary for his health. However, no child who in good faith is under treatment solely by spiritual means through prayer in accordance with the tenets and practices of a recognized church or religious denomination shall for that reason alone be considered to be an abused or neglected child;
3. Whose parents or other person responsible for his care abandons such child;
4. Whose parents or other person responsible for his care commits or allows to be committed any act of sexual exploitation or any sexual act upon a child in violation of the law;
5. Who is without parental care or guardianship caused by the unreasonable absence or the mental or physical incapacity of the child's parent, guardian, legal custodian or other person standing in loco parentis; or
6. Whose parents or other person responsible for his care creates a substantial risk of physical or mental injury by knowingly leaving the child alone in the same dwelling, including an apartment as defined in § 55-79.2, with a person to whom the child is not related by blood or marriage and

who the parent or other person responsible for his care knows has been convicted of an offense against a minor for which registration is required as a violent sexual offender pursuant to § 9.1-902.

An act of child abuse may be committed by any person responsible for the care of another individual who is less than eighteen years of age. It does not matter whether the person caring for the child under the age of 18 (hereinafter referred to as a "Child" or "Children", which term as used in this Policy also includes youth ages 12-18) is a compensated or a volunteer worker. It does not matter whether the person routinely is entrusted with the care of children or whether such individual only occasionally comes in contact with children. It does not matter whether the person was entrusted with the care of a child for an hour or only a moment. It only matters that a child was abused or neglected by the person who, on the occasion in question, was responsible for the child's care.

TYPES OF CHILD ABUSE

1. Definition

Child abuse refers to any act committed by a parent, caregiver or person in a position of trust (even though he or she may not care for the child on a daily basis) which is not accidental and which harms or threatens to harm a child's physical or mental health or welfare. The following definitions and explanations in this section are from the Virginia Department of Social Services.

2. Types of Abuse

A. Physical abuse

- Includes physical injury, threat of injury or creation of a real and significant danger of substantial risk of death, disfigurement or impairment of bodily functions. Such injury or threat of injury, regardless of intent, is inflicted or allowed to be inflicted by non-accidental means. Examples include but are not limited to: asphyxiation (suffocating); bone fracture; brain damage; skull fracture; subdural hematoma (severe bruising); burns and scald injury; cuts; bruises; welts; abrasions; internal injuries; poisoning; sprains; dislocations; gunshot and stabbing wounds.

B. Physical Neglect

- Includes the failure to provide food, clothing, shelter, or supervision for a child if the child's health or safety is endangered. Physical neglect may include multiple occurrences or a one-time critical or severe event that results in a threat to the child's health or safety, such as a toddler left alone. Other types of neglect include, but are not limited to: abandonment; inadequate supervision; inadequate clothing; inadequate shelter; inadequate personal hygiene; inadequate food and malnutrition.

C. Sexual Abuse

- Any act defined in the code of Virginia which is committed or allowed to be committed, upon a child by his or her parent or other persons responsible for the child's care. Examples of such abuse include, but are not limited to: sexual exploitation, sexual molestation, intercourse, sodomy, and other sexual abuse.

D. Medical Neglect

- Refusal or failure by caretaker to obtain and/or follow through with a complete regimen of medical, mental or dental care for a condition, which if untreated, that could result in illness or developmental delays is medical neglect.

E. Failure to Thrive

- Failure to thrive is a syndrome of infancy or early childhood which is characterized

by growth failure, signs of severe malnutrition, and variable degrees of developmental retardation. Children are considered to be in this category only when the syndrome is diagnosed by a physician and is caused by non-organic factors.

F. Mental Abuse/Neglect

- A pattern of acts or omissions by the caretaker which result in harm to a child's psychological or emotional health or development defines mental abuse/neglect.

G. Educational Neglect

- Any action in which the child's caretaker is directly responsible for the failure of the child to attend school or an approved alternative program of study.

H. Bizarre Discipline

- 34. Any action in which the caretaker uses eccentric, irrational or grossly inappropriate procedures or devices to modify the child's behavior is bizarre discipline.